

**HUNTON &
WILLIAMS**



Twentieth National HIPAA Summit HIPAA and Payment & Delivery Reform

Mark S. Hedberg
Partner, Health Care and
Privacy & Data Security Practices
Hunton & Williams LLP
(804) 788-8314
mhedberg@hunton.com

March 27, 2012

Disclaimer

- ➔ These materials and associated remarks are intended as a general discussion of the subject matter addressed. They are not intended to be comprehensive or as legal advice, and they should not be relied upon as such. Attorneys will need to draw their own conclusions relative to any particular case and take into account all applicable laws when formulating advice.

Agenda

- ➔ Context
- ➔ Data Flows
- ➔ HIPAA Privacy Rule Implications

Context

- ➔ The success of health reform depends on transforming the health care payment and delivery systems
- ➔ The Patient Protection and Affordable Care Act set the stage for these fundamental changes

Context

- ⇒ Many reform approaches:
 - ➔ Accountable Care Organizations (ACOs)
 - ➔ Patient-centered medical home
 - ➔ Payment bundling for episodes of care
 - ➔ Center for Medicare & Medicaid Innovation
 - ↳ Comprehensive Primary Care Initiative
 - ↳ Chronic Disease Prevention (state grants)
 - ↳ Reducing Avoidable Hospitalizations for Nursing Facility Residents

Context

- ➔ Common thread: all depend on detailed, timely and crunchable data
- ➔ Electronic Health Records are essential
- ➔ HIPAA is highly relevant because of the need to collect and transmit data within these new approaches

Internal Data Flows

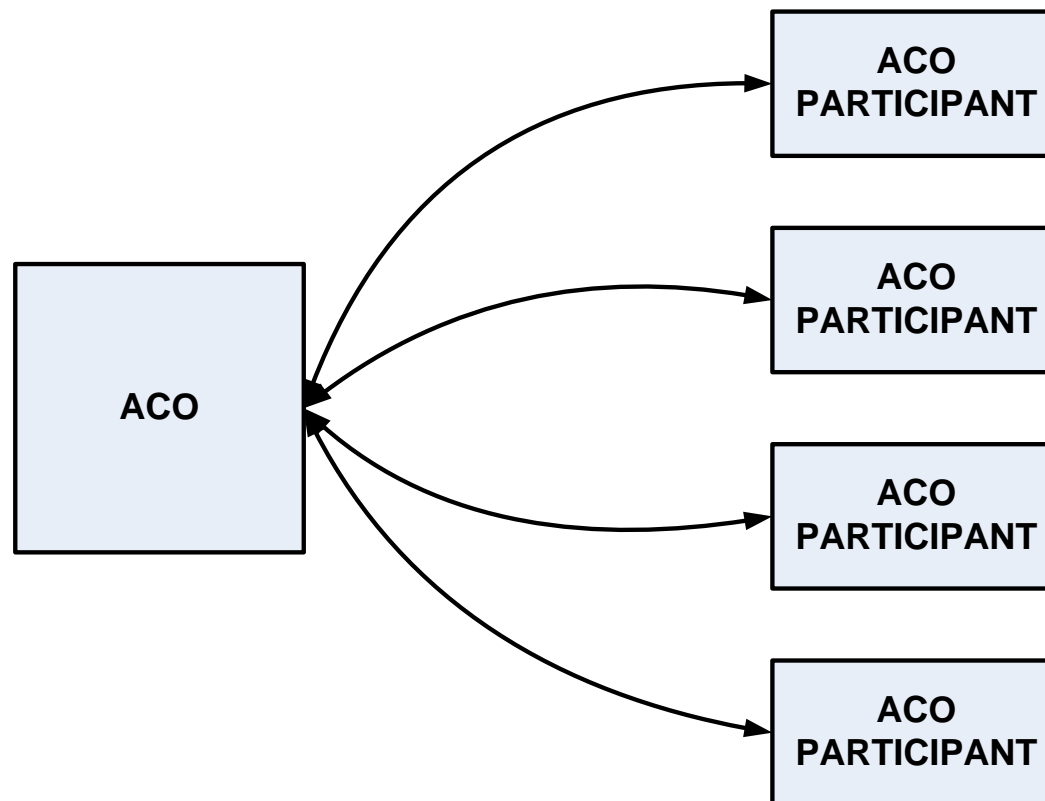

External Data Flows

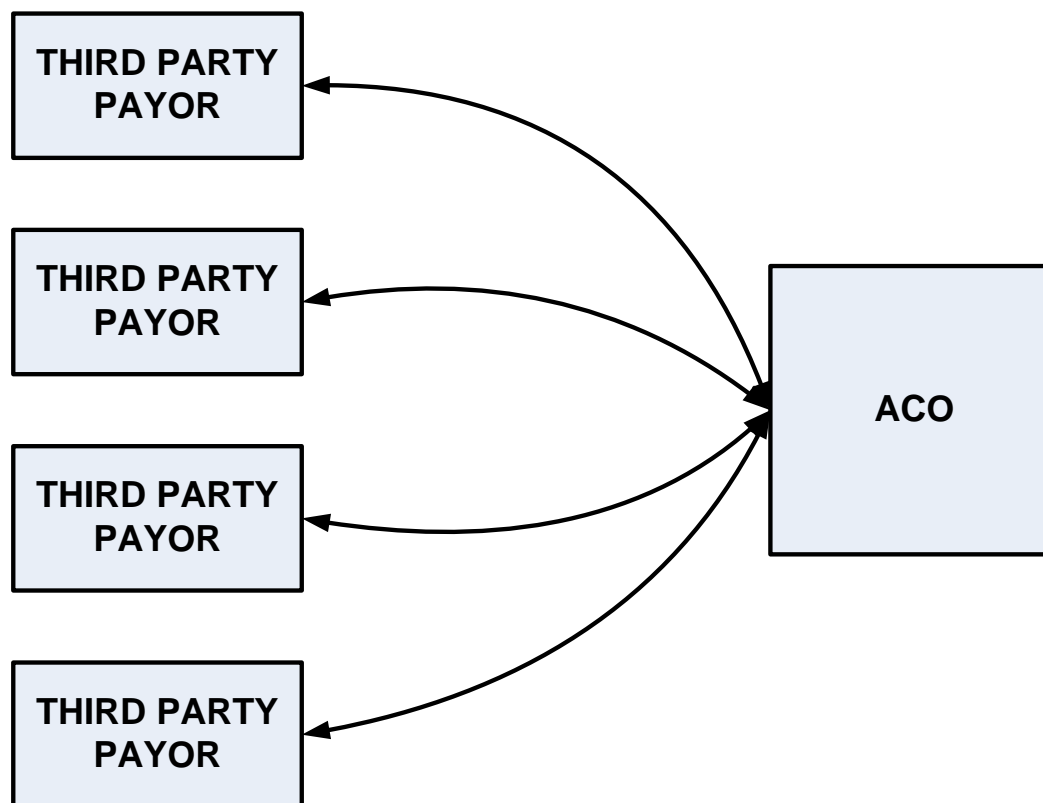

Data Flow – Consolidated View

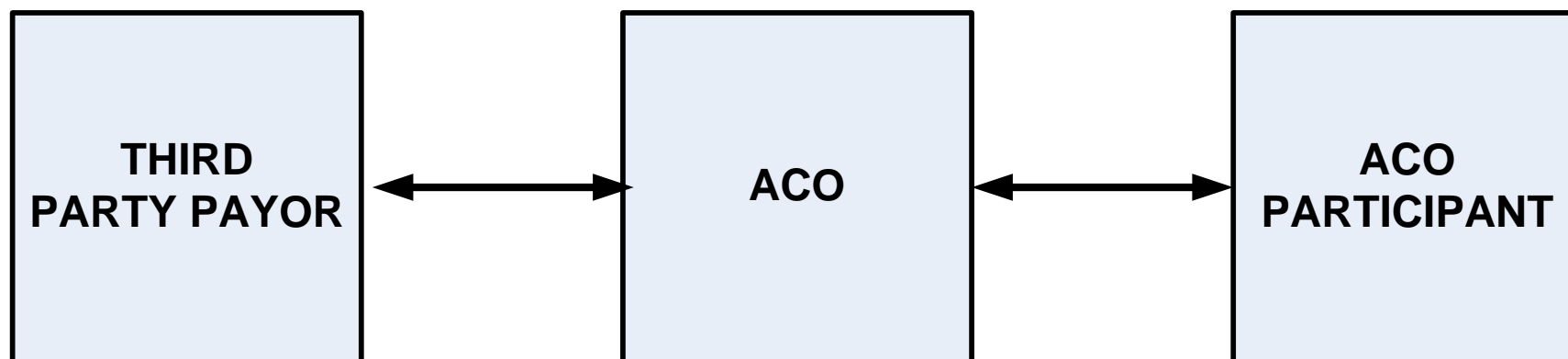

DATA FLOW - HIE

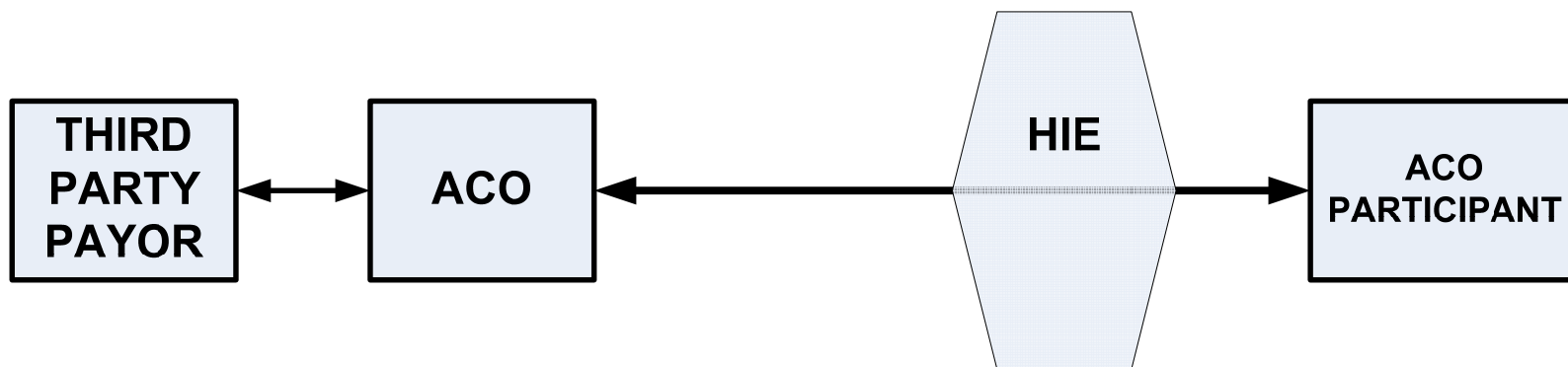

DATA FLOW – HIE & ACO SUBCONTRACTOR (ACO SUBC)

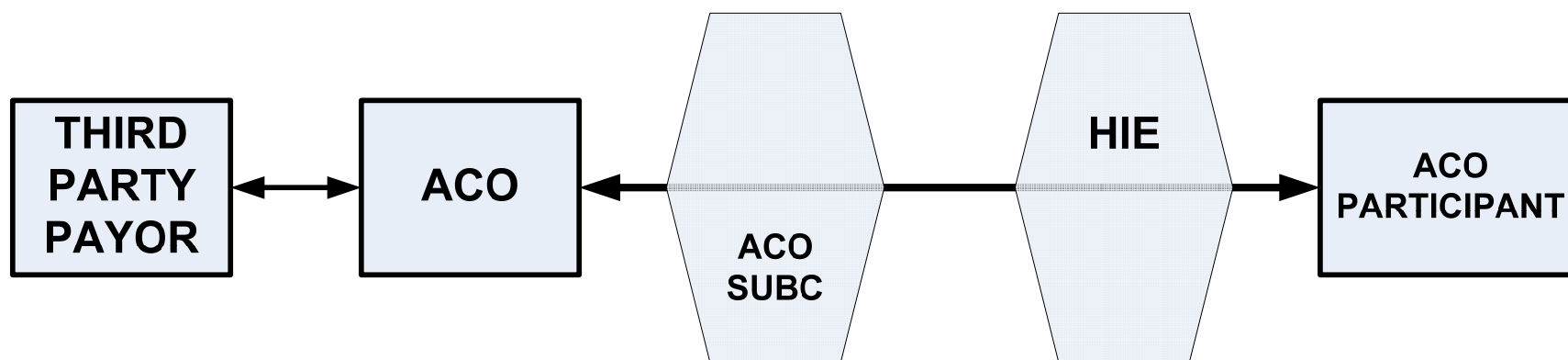

DATA FLOW – HIE & ACO SUBCONTRACTOR

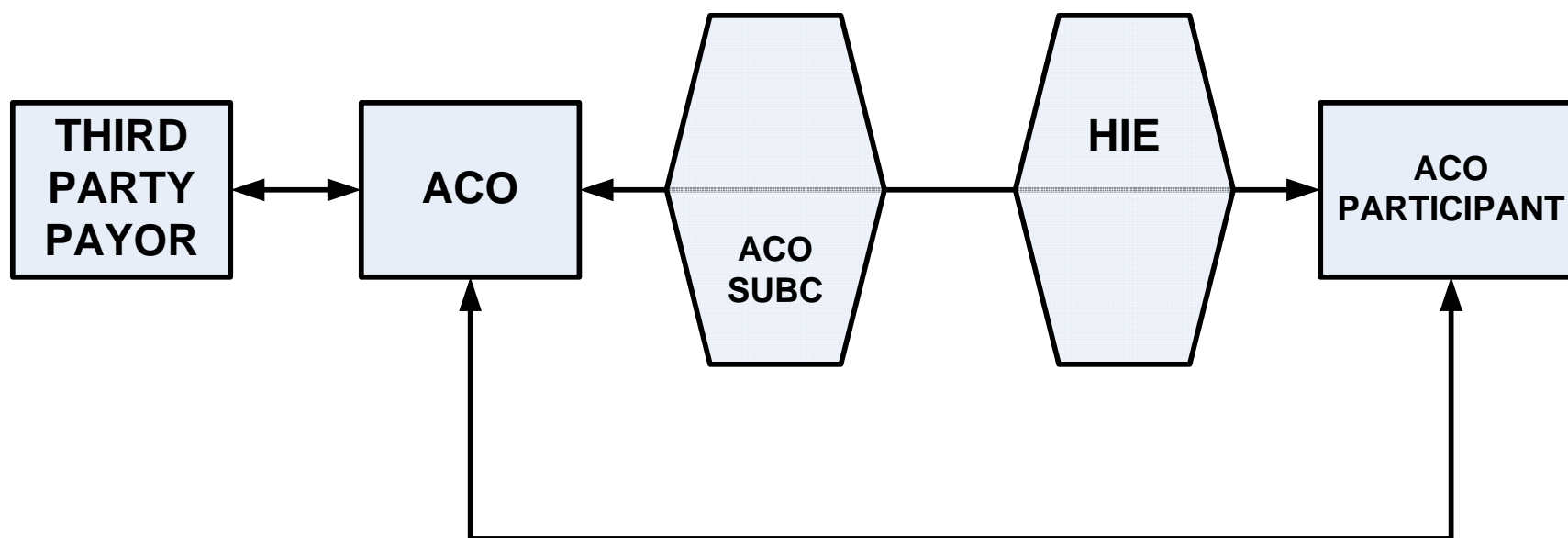

DATA FLOW – HIE & ACO SUBCONTRACTOR

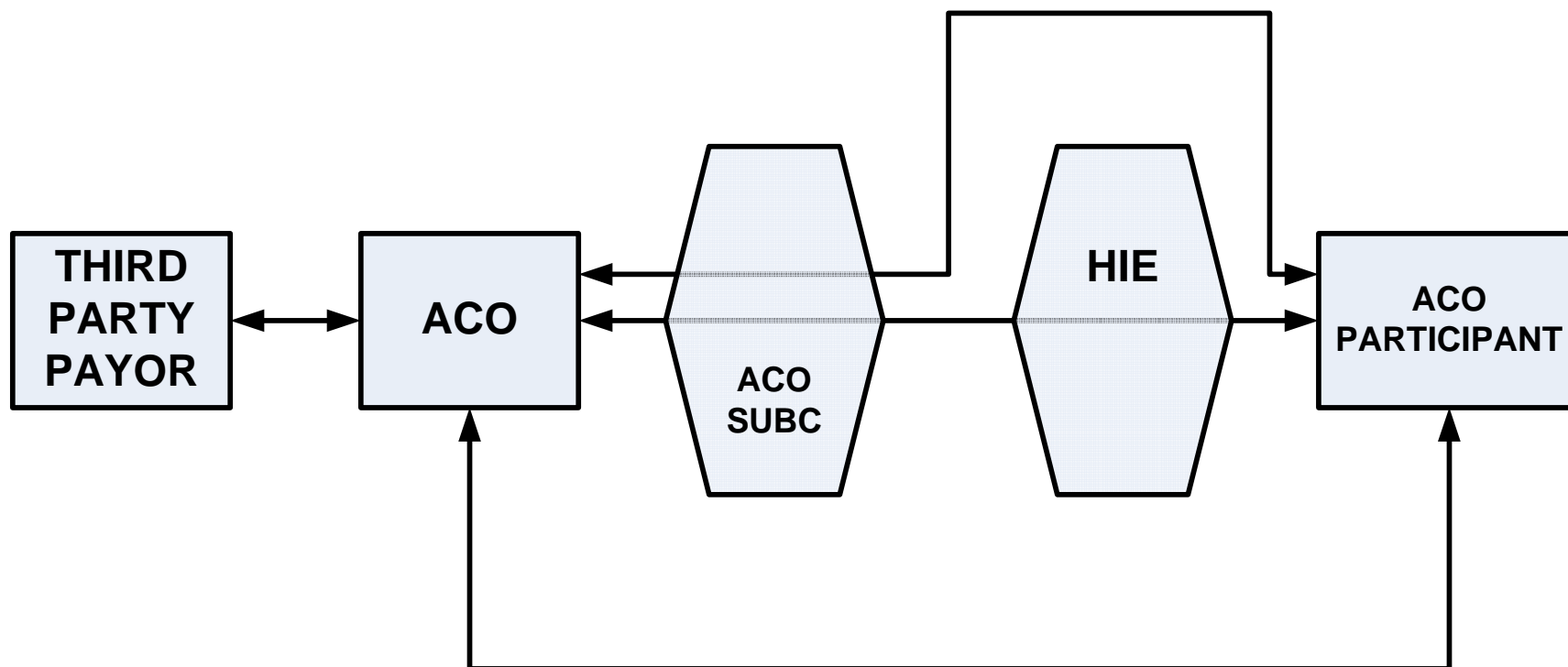

DATA FLOW – HIE & ACO SUBCONTRACTOR

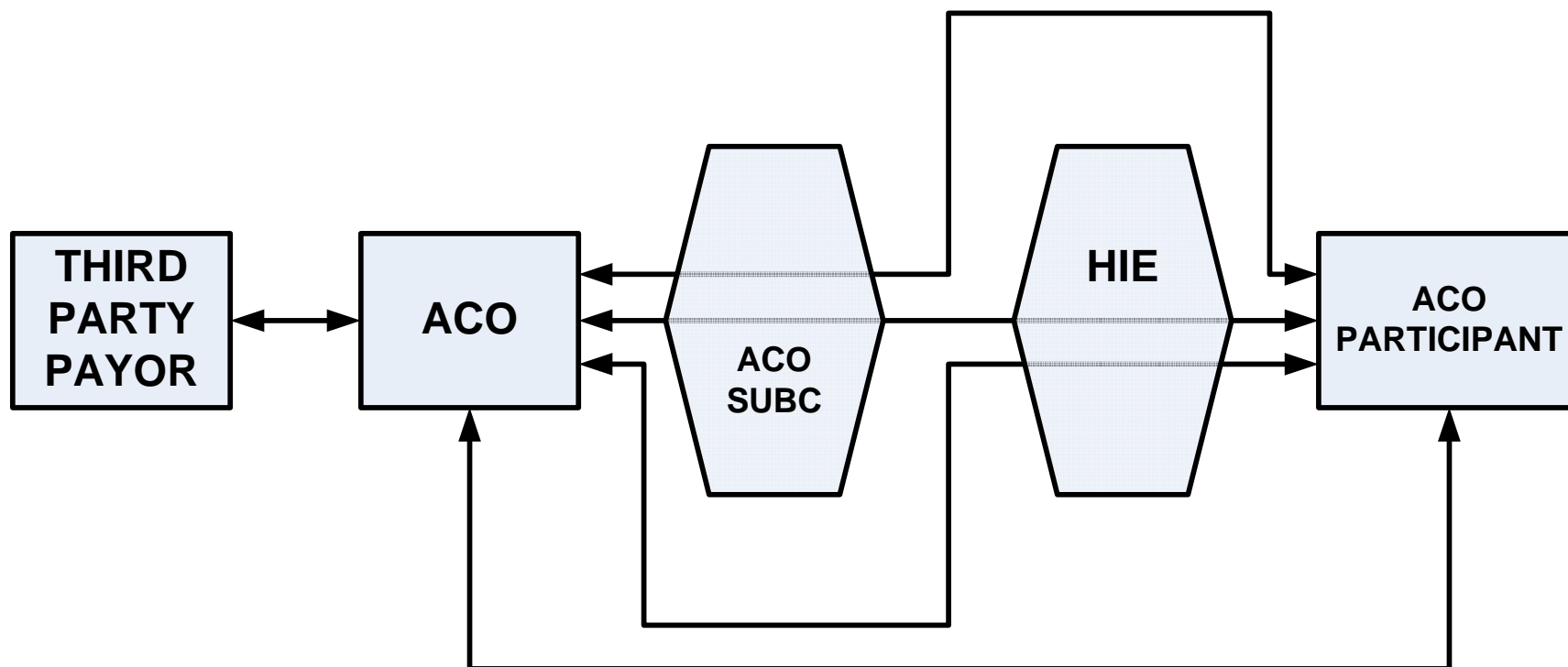

CONTRACTS

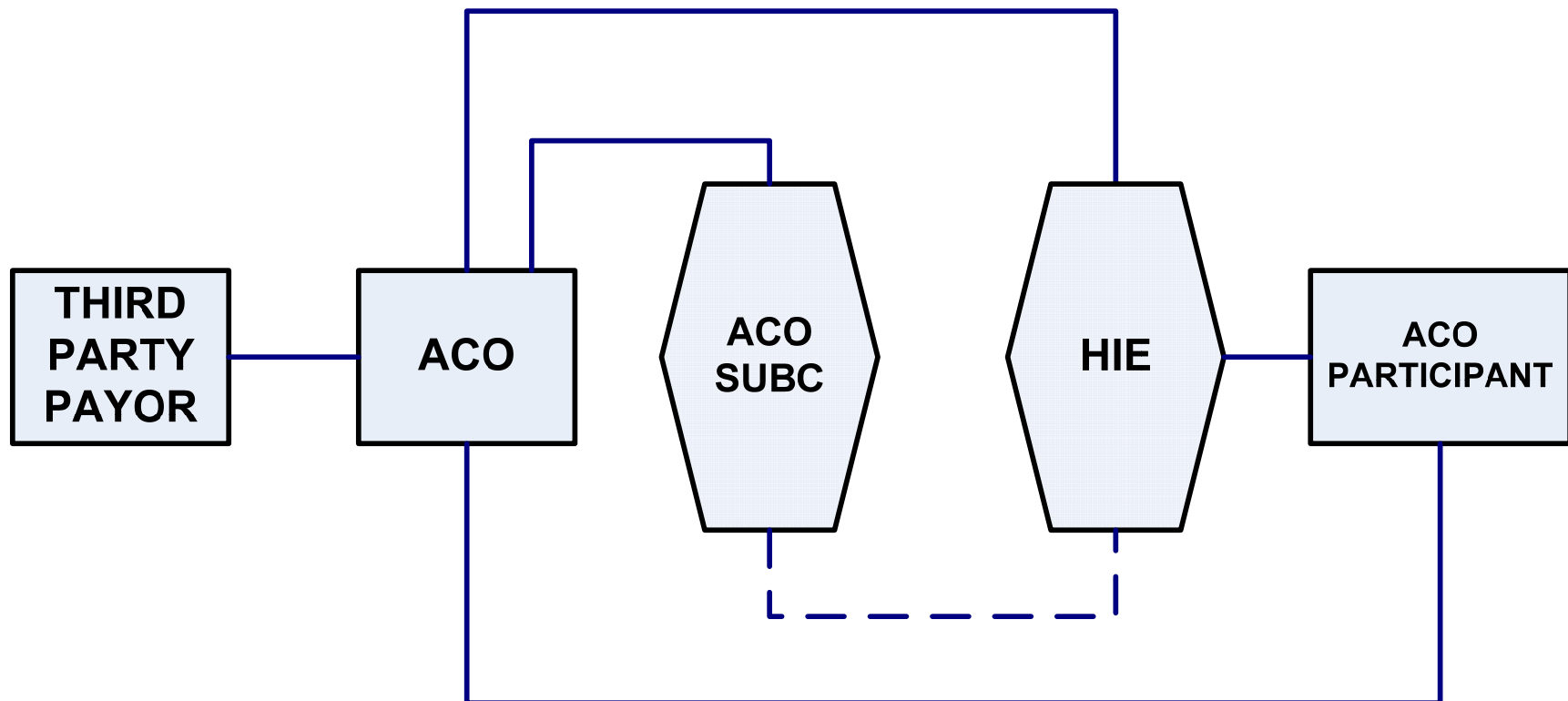

Questions?

Mark S. Hedberg

Partner, Health Care and
Privacy & Data Security Practices

Hunton & Williams LLP

(804) 788-8314

mhedberg@hunton.com